

FEATURES

- 2 x 0-10VDC individual outputs for valve control.
- 4 individual outputs (suitable for capacitive loads, maximum 140µF) capable of controlling up to 4 fan speeds.
- 4 analog/digital inputs.
- Manual output operation in 0-10VDC and individual outputs with push button and status indicator LED.
- Logic functions.
- Output timing facilities.
- Total data saving on power failure.
- DIN rail unit assembly (EN 50022), with snap fit clamp.
- Size 67 x 90 x 80 mm (4.5 DIN units).
- KNX BCU integrated
- Possibility to connect different phases in adjacent outputs.
- Conformity with the CE directives (CE-mark on the right side).

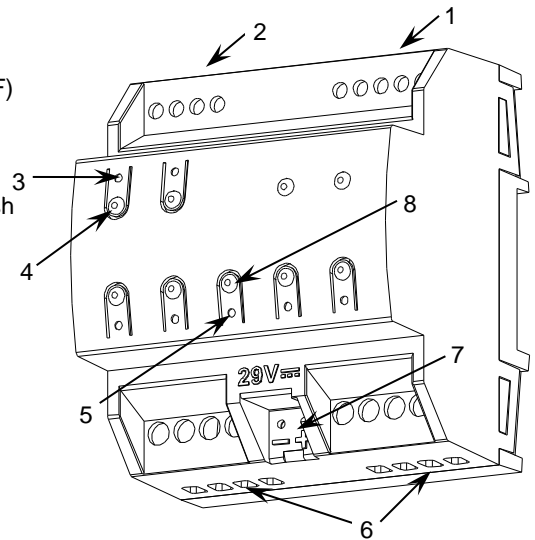

Figure 1: MAXinBOX FC 0-10V VALVE

1. Analog/Digital inputs	2. 0-10VDC outputs	3. Output status LED indicator	4. Output control button
5. Programming/Test LED	6. Lower outputs	7. KNX connection	8. Programming/Test button

Programming/Test button: short press to set programming mode. If this button is held while plugging the device into the KNX bus, it enters the safe mode. If this button is held for more than 3 seconds, the device enters the test mode.

Programming/Test LED: programming mode indicator (red). When the device enters the safe mode, it blinks (red) every half second. The manual mode is indicated by the green color. During the start-up (reset or after KNX bus failure) and if the device is not in safe mode, it starts a blue blinking sequence.

GENERAL SPECIFICATIONS

CONCEPT		DESCRIPTION		
Type of device		Electric operation control device		
KNX supply	Voltage (typical)	29VDC SELV		
	Voltage range	21..31VDC		
	Maximum consumption	Voltage	mA	mW
		29VDC (typical)	11	319
24VDC ¹	15	360		
Connection type		Typical TP1 bus connector for 0.80mm Ø rigid cable		
External power supply		Not required		
Operation temperature		0°C .. +55°C		
Storage temperature		-20°C .. +55°C		
Operation humidity		5 .. 95% (No condens.)		
Storage humidity		5 .. 95% (No condens.)		
Complementary characteristics		Class B		
Protection class		II		
Operation type		Continuous operation		
Device action type		Type 1		
Electrical stress period		Long		
Degree of protection		IP20, clean environment		
Installation		Independent device to be mounted inside electrical panels with DIN rail (EN 50022)		
Minimum clearances		Not required		
Response on KNX bus failure		Data saving according to parameterization		
Response on KNX bus restart		Data recovery according to parameterization		
Operation indicator		The programming LED indicates programming mode (red) and test mode (green). Each output LED indicates its status		
Weight		248g		
PCB CTI index		175V		
Housing material		PC FR V0 halogen free		

¹ Maximum consumption in the worst case scenario (KNX Fan-In model)

OUTPUTS SPECIFICATIONS AND CONNECTIONS		
CONCEPT		DESCRIPTION
Number of outputs		4
Output type		Potential-free outputs through bistable relays with tungsten pre-contact / Micro-disconnection
Rated current per output		AC 16(6)A @ 250VAC (4000VA) DC 7A @ 30VDC (210W)
Maximum load per output	Resistive	4000W
	Inductive	1500VA
Maximum inrush current		800A/200µs 165A/20ms
Connections in adjacent outputs		Possibility of connecting different phases. It is not allowed to connect power supplies of different order, SELV with NO SELV, in the same block
Maximum current per block		40A
Connection method		Screw terminal block
Cable cross-section		1.5-4mm ² (IEC) / 26-10AWG (UL)
Outputs per common		1
Maximum response time		10ms
Mechanical lifetime (min. cycles)		3 000 000

0-10V OUTPUT SPECIFICATIONS AND CONNECTIONS	
CONCEPT	DESCRIPTION
Número de salidas	2
Output type	0-10VDC
Maximum load per output	1.5mA
Connection method	Screw terminal block
Cable cross-section	0.5-2.5mm ² (IEC) / 26-12AWG (UL)
Maximum cable length	30m
Output per common	1

INPUTS SPECIFICATIONS AND CONNECTIONS	
CONCEPT	DESCRIPTION
Number of inputs	4
Inputs per common	4
Operation voltage	+3.3VDC in the common
Operation current	1mA @ 3.3VDC (per input)
Switching type	Dry voltage contacts between input and common
Connection method	Screw terminal block
Cable cross-section	0.5-2.5mm ² (IEC) / 26-12AWG (UL)
Maximum cable length	30m
NTC probe length	1.5m (up to 30m)
NTC accuracy (@ 25°C)	±0.5°C
Temperature resolution	0.1°C
Maximum response time	10ms

INPUTS CONNECTION

Any combination of the next accessories is allowed on the inputs:

Temperature Probe

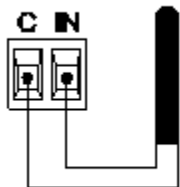

Zennio temperature probe.

Motion Sensor



Up to two motion sensors can be plugged into the same device input (parallel wiring)

Motion sensor screw terminal.

Motion sensor references:
ZN110-DETEC-X
ZN110-DETEC-P*

Switch/Sensor/ Push button

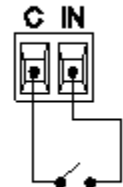

* The micro switch number 2 in the ZN110-DETEC-P must be in **Type B position** to work properly.

SAFETY INSTRUCTIONS

- Installation should only be performed by qualified professionals according to the laws and regulations applicable in each country.
- Do not connect the mains voltage nor any other external voltage to any point of the KNX bus; it would represent a risk for the entire KNX system. The facility must have enough insulation between the mains (or auxiliary) voltage and the KNX bus or the wires of other accessories, in case of being installed.
- Once the device is installed (in the panel or box), it must not be accessible from outside.
- Keep the device away from water and do not cover it with clothes, paper or any other material while in use.
- The WEEE logo means that this device contains electronic parts and it must be properly disposed of by following the instructions at <http://zennio.com/weee-regulation>.

WIRING DIAGRAMS

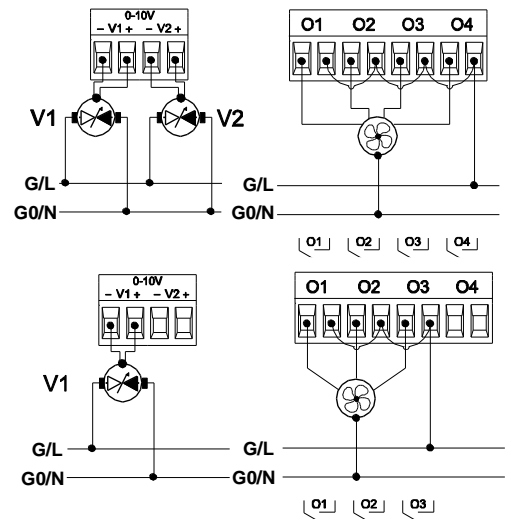

Figure 2: wiring example for 4-pipe fan coil with 4-speed fan (up) and for 2-pipe fan coil with 3-speed fan (down).

0-10V outputs according to the number of fan coil pipes:

Fan Coil	0-10V output	Valve function
4 pipes	V1	Cooling valve
	V2	Heating valve
2 pipes	V1	Cooling and/or heating valve

△ In order to ensure the expected status of the relays, please check that the device is connected to the KNX bus before energizing the power circuit.

Attaching MAXinBOX FC 0-10V VALVE to DIN rail:

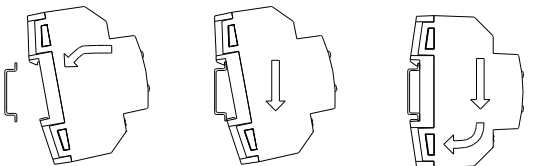

Removing MAXinBOX FC 0-10V VALVE from DIN rail:

