

FEATURES

- 4 constant voltage channels configurables (independent channels, RGBW channels and RGB+W channels).
- 6 analog/digital inputs.
- Master Light control.
- External 12-30VDC power supply.
- Manual output operation with push button and LED status indicator.
- Total data saving on KNX bus failure.
- Integrated KNX BCU.
- Dimensions 60 x 90 x 79mm (4,5 DIN units).
- DIN rail mounting (EN 50022), through pressure.
- Conformity with the CE directives (CE-mark on the right side).

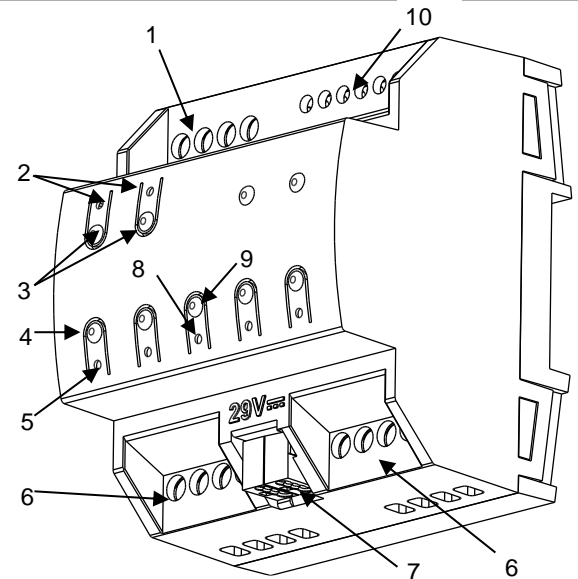

Figure 1: Lumento DX4

1. External power supply	2. Colour shift status LED*	3. Colour shift control buttons*	4. Channel control button	5. Channel status LED
6. Output channels	7. KNX connector	8. Programming/Test LED	9. Programming/Test button	10. Inputs

Programming/Test button: short press to set programming mode. If this button is held while plugging the device into the KNX bus, it enters the safe mode. If this button is held for more than 3 seconds, the device enters the test mode.

Programming/Test LED: programming mode indicator (red). When the device enters the safe mode, it blinks (red) every half second. The manual mode is indicated by the green color. During the start-up (reset or after KNX bus failure) and if the device is not in safe mode, it emits a red flash. A blue blink represents an error.

GENERAL SPECIFICATIONS

CONCEPT		DESCRIPTION		
Type of device		Electric operation control device		
KNX supply	Voltage (typical)	29VDC SELV		
	Voltage range	21..31VDC		
	Maximum consumption	Voltage	mA	mW
		29VDC (typical)	6.5	188.5
24VDC ¹	10	240		
Connection type		Typical TP1 bus connector for 0.80mm Ø rigid cable		
External power supply		12-30VDC		
Operation temperature		0°C .. +55°C		
Storage temperature		-20°C .. +55°C		
Operation humidity		5 .. 95% (No condens.)		
Storage humidity		5 .. 95% (No condens.)		
Complementary characteristics		Class B		
Protection class		III		
Operation type		Continuous operation		
Device action type		Type 1		
Electrical stress period		Long		
Degree of protection		IP20, clean environment		
Installation		Independent device to be mounted inside electrical panels with DIN rail (EN 50022)		
Minimum clearances		Not required		
Response on KNX bus failure		Data saving according to parameterization		
Response on KNX bus restart		Data recovery according to parameterization		
Operation indicator		The programming LED indicates programming mode (red), test mode (green) and error (blue blinking). Colour shift LEDs show the current colour. Each output LED indicates its status.		
Weight		184g		
PCB CTI index		175V		
Housing material		PC FR V0 halogen free		

¹ Maximum consumption in the worst case scenario (KNX Fan-In model)

OUTPUTS SPECIFICATIONS AND CONNECTIONS	
CONCEPT	DESCRIPTION
Number of outputs	4
Output type	Solid state switching device
Maximum load per output	6A
Load type	LED strip (monochrome, RGB or RGBW) with common anode (+)
Short-circuit protection	YES
Overload protection	YES
Overheating protection	YES
Connection method	Screw terminal block
Cable cross-section	0.5-4mm ² (IEC) / 10-30AWG (UL)

EXTERNAL POWER SUPPLY SPECIFICATIONS AND CONNECTIONS	
CONCEPT	DESCRIPTION
Voltage	12-30VDC (voltage in concordance with voltage LED strips to be connected)
Current	Depending upon the load to be controlled up to a maximum of 24A
Connection method	Screw terminal block
Cable cross-section	0.5-4mm ² (IEC) / 10-30AWG (UL)

INPUTS SPECIFICATIONS AND CONNECTIONS	
CONCEPT	DESCRIPTION
Number of inputs	6
Inputs per common	6
Operation voltage	+3.3VDC in the common
Operation current	1mA @ 3.3VDC (per input)
Switching type	Dry voltage contacts between input and common
Connection method	Screw terminal block
Cable cross-section	0.5-2.5mm ² (IEC) / 26-12AWG (UL)
Maximum cable length	30m
Maximum response time	10ms

WIRING DIAGRAMS

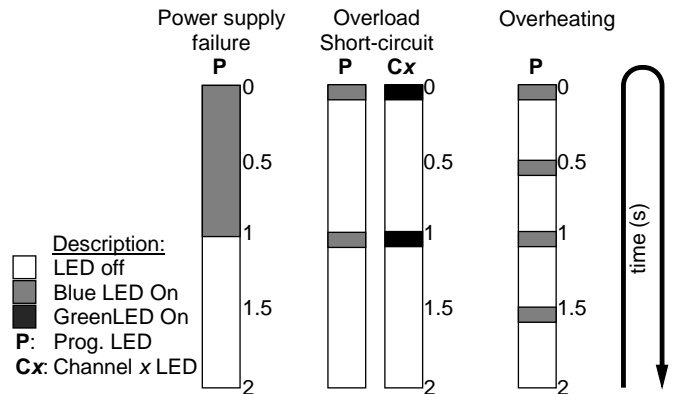
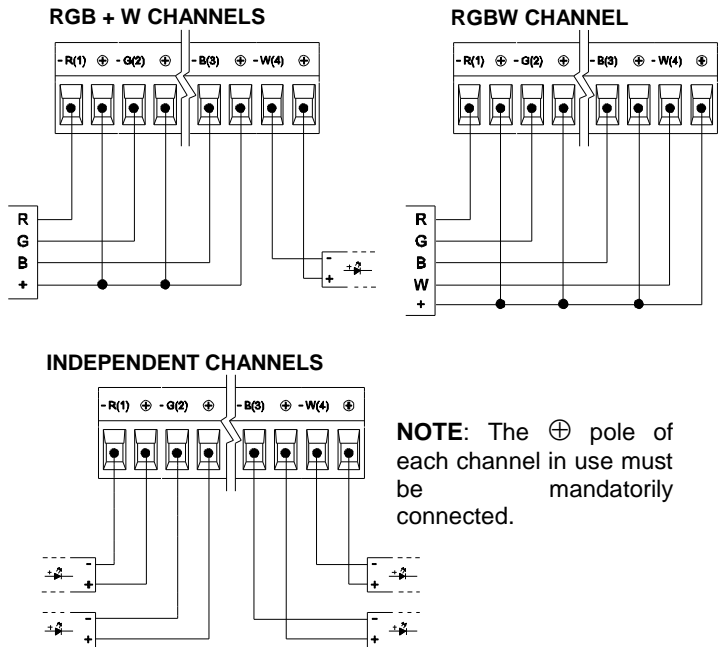
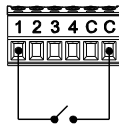

Figure 2: Error notification LED codes

INPUTS CONNECTION

Any combination of the next accessories is allowed on the inputs:

Switch/Sensor/ Push button



Motion Sensor

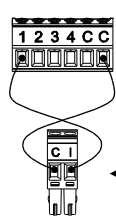

Up to two motion sensors can be plugged into the same device input (parallel wiring)

Motion sensor screw terminal.

Motion sensor references:
 ZN110-DETEC-X
 ZN110-DETEC-P

* The micro switch number 2 in the ZN110-DETEC-P must be in **Type B** position to work properly.

Attaching Lumento DX4 to DIN rail:

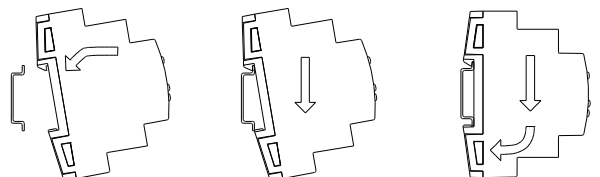

Removing Lumento DX4 from DIN rail:

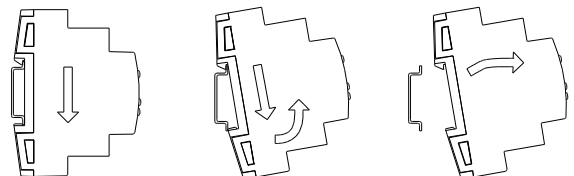

SAFETY INSTRUCTIONS

- ⚠ Installation should only be performed by qualified professionals according to the laws and regulations applicable in each country.
- Do not connect the mains voltage nor any other external voltage to any point of the KNX bus; it would represent a risk for the entire KNX system. The facility must have enough insulation between the mains (or auxiliary) voltage and the KNX bus or the wires of other accessories, in case of being installed.
- The facility must be equipped with a device that ensures the omnipolar sectioning. Installation of a 10A mini-circuit-breaker is recommended. To prevent accidents, it must remain open in case of manipulation of the device.
- Once the device is installed (in the panel or box), it must not be accessible from outside.
- Keep the device away from water and do not cover it with clothes, paper or any other material while in use.
- ⚠ The WEEE logo means that this device contains electronic parts and it must be properly disposed of by following the instructions at <http://zennio.com/weee-regulation>.